



Smart solutions.
Strong relationships.



VSM SERIES DRIVES

Powering Efficiency, Reliability, and Productivity
in Industrial Automation



VSM AC Drives:

Powering Efficiency, Reliability, and Productivity in Industrial Automation



The VSM AC drive is designed to fulfill all the standard automation needs in today's rapidly advancing environment. Not only does it conserve energy effectively, but it also offers ease operation, providing a speedy solution for commissioning tasks. VSM presents a cost-efficient, secure, and energy-efficient solution tailored for the rigorous industrial settings. VSM drives cater to the needs of process owners, proving ideal for various applications such as fans, pumps, blowers, and compressors.

Main Features:

- Excellent performance with high start torque characteristic.
- High-precision torque control, V/f separated control, torque control at sensor-less vector control.
- Optimized and compact structural design, leading technology platform.
- Supports both Induction motor and permanent magnet motor.
- Strong overload capability with 200% of rated load for 1 sec.
- Standard rated for 50 °C.
- Heavy duty drive for various applications.
- Built in brake chopper.
- Built-in PLC logic functions, virtual digital I/O's with multi logic functions, timer and comparators.
- Efficient cooling, improved reliability with independent air and duct design.



Model Explanation:

Model Shown on the Product Nameplate Showcases the Following Information.

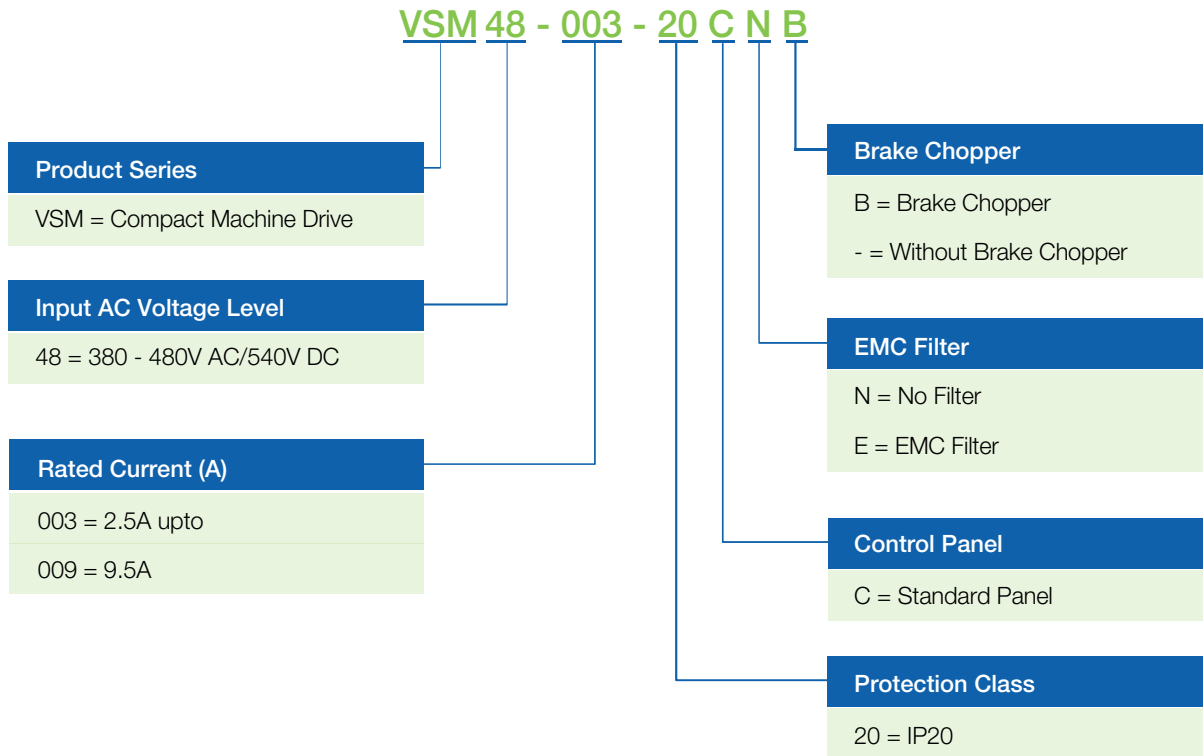

Note: '-XS' suffix denotes drive with 7 segment LCD display.

Types and Ratings - VSM Series 3-Phase, 415V:

Model No.	Power Capacity kVA	Rated Input Current	Rated Output Current	Applicable Motor	
		A	A	kW	HP
VSM48-003-20CNB	1.5	3.4	2.5	0.75	1
VSM48-004-20CNB	3.0	5.0	4.2	1.5	2
VSM48-006-20CNB	4.0	5.8	5.5	2.2	3
VSM48-009-20CNB	6.0	11	9.5	3.7, 4	5



General Specifications of Compact Machine Drives:

Function		Specifications
Power Input	Rated Input Voltage (V)	3-phase 415V (-20% ~ +20%)
	Rated Input Frequency (Hz)	50Hz/60Hz, tolerance $\pm 5\%$
Power Output	The Maximum Output Voltage (V)	0 ~ rated input voltage, error $< \pm 3\%$
	The Maximum Output Frequency (Hz)	0 ~ 590 Hz, resolution 0.01Hz
Control Characteristics	V/f Patterns	V/f control Sensor-less vector control 1 & 2
	Speed Range	1:50 (V/f control) 1:100 (sensor-less vector control 1) 1:200 (sensor-less vector control 2)
	Speed Accuracy	$\pm 0.5\%$ (V/f control) $\pm 0.2\%$ (sensor-less vector control 1 & 2)
	Speed Fluctuation	$\pm 0.3\%$ (sensor-less vector control 1 & 2)
	Torque Response	$< 10\text{ms}$ (sensor-less vector control 1 & 2)
	Starting Torque	0.5Hz: 180% (V/f control, sensor-less vector control 1) 0.25Hz: 180% (sensor-less vector control 2)
Basic Functions	Overload Capability	150% Rated Current 60s, 180% Rated Current 10s, 200% Rated Current 1s.
Protection Function	Overcurrent, Overvoltage, Under Voltage, Over Temperature, Overload etc. Protection.	
Environment	Place of Operation	Indoors, no direct sunlight, free from dust, corrosive gases, flammable gases, oil mist, water vapour, water drop and salt, etc.
	Altitude	0 ~ 2000m De-rate 1% for every 100m when the altitude is above 1000m
	Ambient Temperature	-10 °C ~ 50 °C
	Relative Humidity	5 ~ 95%, no condensation
	Vibration	Less than 5.9m/s ² (0.6g)
	Storage Temperature	-20 °C ~ +70 °C
Others	Efficiency	Rated power $\geq 93\%$
	Installation	Wall-mounted or flange mounting
	IP Grade	IP20
	Cooling Method	Fan cooled

Wiring Diagram:

VSM (0.75~4kW):

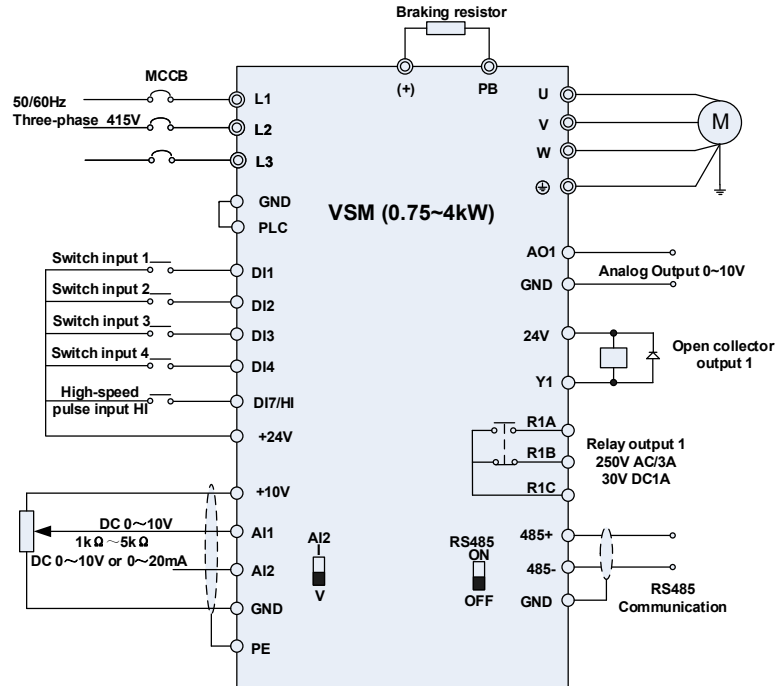

Model Mounting & Design:

0.75~4kW Dimensions and Wall Mounting Dimensions:

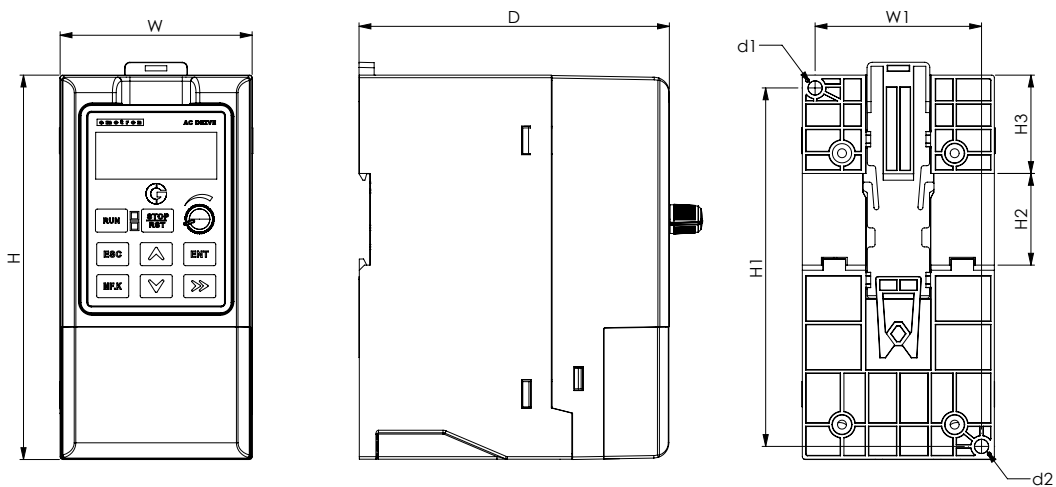

Mechanical Specifications for VSM Model:

Model No.	External and Installation Dimensions (mm)									Weight (kg)	Air Flow (CFM)
	W	H	D	W1	H1	H2	H3	Install Hole (d1)	Install Hole (d2)		
VSM48-003-20CNB	75	150	120	65	140	35	38.5	4.5	4.5	0.95	10
VSM48-004-20CNB											15
VSM48-006-20CNB	93	171	130	82	160	35	39	4.5	4.5	1.45	15
VSM48-009-20CNB											15

Terminals of VSM48:

Model	VSM48	Functional Description
	0.75~4kW	
DI	5 (DI1~DI4, DI7)	Maximum input frequency: 200Hz, (100kHz for D7) Impedance:2.4kΩ Voltage range for level input: 9V ~ 30V
DO	1 (Y1)	Voltage range:0 ~ 24V Current range:0 ~ 50mA
AI	2 (AI1, AI2)	Input voltage range: DC 0 ~ 10V/0 ~ 20mA Impedance: 250kΩ (voltage input), 250Ω (current input)
AO	1 (AO1)	Output voltage range: DC 0 ~ 10V/0 ~ 20mA Impedance requirements≥10kΩ
RO	1 (R1)	Contact driving capacity: AC 250V, 3A, CosØ=0.4, DC 30V, 1A
RS485	1 (485+, 485-)	Rate: 4800/9600/19200/38400/57600/115200bps

Accessories:

Standard Option	Part No.	Description	Connection Mode
Keypad - Basic	PPU-VSmicro	LED display	RJ45
Keypad - Standard	S-PPU-VSmicro	LCD display	RJ45
Profibus Card	VSPROFIBUS-DP	Profibus communication card	DB9

Application Software:

EmoWizard software helps in the easy commissioning and troubleshooting of VSM series drives, offering user-friendly tools for viewing, manipulation, and exchanging data with the drive. Statistics data can be plotted using the oscilloscope, and drive control with control panel.

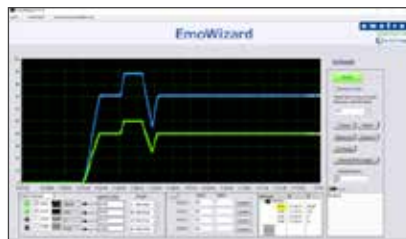

Applications:



Conveyors



Pumps



Washing Machines



Industrial Fans

VSM series drives can also be used in a variety of three-phase compact machine applications beyond these applications, offering excellent performance with high torque characteristics.

Other Products from CG Drives and Automation:



Emotron FDU & VFX 2.1

Variable / Constant Torque Drive Applications.

Rated Power	0.55-4,000 kW
Supply Voltage	230-690 V, 3-phase



Emotron Active Front End Drive (AFE)

Available as Low Harmonic or Regenerative Version.

Rated Power	55-2,200 kW (AC) / 200-4,000 kW
Supply Voltage	380-690 V (AC) / 380-690 V, 3-phase



Emotron VSX

Compact Machinery Drive with High Functionality.

Rated Power	VSX48: 0.75-55 kW, 3-phase
Supply Voltage	380-480 V, 3-phase



Emotron VSR

Solar Drive with High Functionality.

Rated Power	VSR48: 0.75-55 kW, 3-phase
	VSRE48: 0.75-4 kW, 3-phase
	VSR23: 0.37-4 kW, 1-phase
	VSR11: 1.1 kW, 1-phase
Supply Voltage	110 / 230 V 1-phase, 380-480 V 3-phase



Emotron TSA

Starts, Stops and Protects.

Rated Power	5.5-1,000 kW
Supply Voltage	230-690 V, 3-phase



Emotron M20

Shaft Power Monitors

Rated Power	100-240/380-500/525-690 VAC
Supply Voltage	Up to 999A via current transformer

Registered Office

CG Power and Industrial Solutions Limited
CG House, 6th Floor, Dr. Annie Besant Road, Worli, Mumbai 400 030, Maharashtra, India
Phone: +91 022 2423 7700

Manufacturing Location

CG Drives and Automation
Plot#9, MPAKVN, Phase-2, New Industrial Area, Mandideep 462 046, M.P.
Phone: 0748 0426427 / 440 / 441 / 456 / 435

CG Drives & Automation Sweden AB
Morsaregatan 12, Box 222 25
SE-250 24 Helsingborg, Sweden
Tel: +46 42 16 99 00

Regional Sales Office

North: 4th Floor, Discovery Tower, Plot No. A-17, Sector 62, Noida, Gautam Budh Nagar, 210 309, India
Tel: +91 (0) 120 4229478
East: 50 Chowringhee Road, Kolkata 700 071, West Bengal, India, Tel: +91 (0) 33 2282 9681/85
West: CG House, 8th Floor, Dr. Annie Besant Road, Worli, Mumbai 400 030, Maharashtra, India
Tel: +91 (0) 22 2423 8940
South: No-3, Dr. MGR Salai (Kodambakkam High Road), Nungambakkam, Chennai 600 034, Tamil Nadu, India,
Tel: +91 (0) 44 4224 7500

Email: drives.mktg@cgglobal.com | drives.service@cgglobal.com
Econnect: <http://itapp.cgglobal.com/Econnect/>

Our All India Service Center Toll Free No: 1800 267 0505

For more information visit:

www.cgglobal.com | www.emotron.com

